

Product data sheet

Characteristics

QOU350

Mini circuit breaker, QOU, 50A, 3 pole, 240 VAC, 10kA

Product availability : Stock - Normally stocked in distribution facility



Main

Product or component type	Miniature circuit-breaker
Range of product	QOU
Circuit breaker type	Standard
Circuit breaker application	HACR and Switching Duty rated

Complementary

Line Rated Current	50 A
Electrical connection	Slotted box lugs, line side Slotted box lugs, load side
[Ue] rated operational voltage	120/240 V AC 240 V AC 120 V AC 48 V DC
Mounting mode	Unit mount
AWG gauge	AWG 14...AWG 2 aluminium/copper
Height	4.05 in (102.87 mm)
Width	2.25 in (57.15 mm)
Depth	2.95 in (74.93 mm)
Tightening torque	45 lbf.in (5.08 N.m) AWG 14...AWG 2)

Environment

Product certifications	CSA IEC UL Listed
------------------------	-------------------------

* Price is "List Price" and may be subject to a trade discount – check with your local distributor or retailer for actual price.

Ordering and shipping details

Category	00900 - QOU BREAKERS & SWITCH
Discount Schedule	DE2
GTIN	00785901418986
Nbr. of units in pkg.	16
Package weight(Lbs)	16 lb(US) (7.26 kg)
Returnability	Yes
Country of origin	MX

Packing Units

Unit Type of Package 1	PCE
Package 1 Height	3.50 in (8.89 cm)
Package 1 width	4.80 in (12.192 cm)
Package 1 Length	2.60 in (6.604 cm)
Unit Type of Package 2	CAR
Number of Units in Package 2	5
Package 2 Weight	23.20 lb(US) (10.523 kg)
Package 2 Height	3.50 in (8.89 cm)
Package 2 width	13.50 in (34.29 cm)
Package 2 Length	20.50 in (52.07 cm)
Unit Type of Package 3	PAL
Number of Units in Package 3	840
Package 3 Weight	966.00 lb(US) (438.17 kg)
Package 3 Height	40.00 in (101.6 cm)
Package 3 width	40.00 in (101.6 cm)
Package 3 Length	48.00 in (121.92 cm)

Offer Sustainability

Sustainable offer status	Green Premium product
REACH Regulation	REACH Declaration
REACH free of SVHC	Yes
EU RoHS Directive	Compliant EU RoHS Declaration
Toxic heavy metal free	Yes
Mercury free	Yes
RoHS exemption information	Yes
China RoHS Regulation	China RoHS declaration Pro-active China RoHS declaration (out of China RoHS legal scope)
Environmental Disclosure	Product Environmental Profile
Halogen content performance	Halogen free product

Contractual warranty

Warranty	18 months
----------	-----------

Dimensions

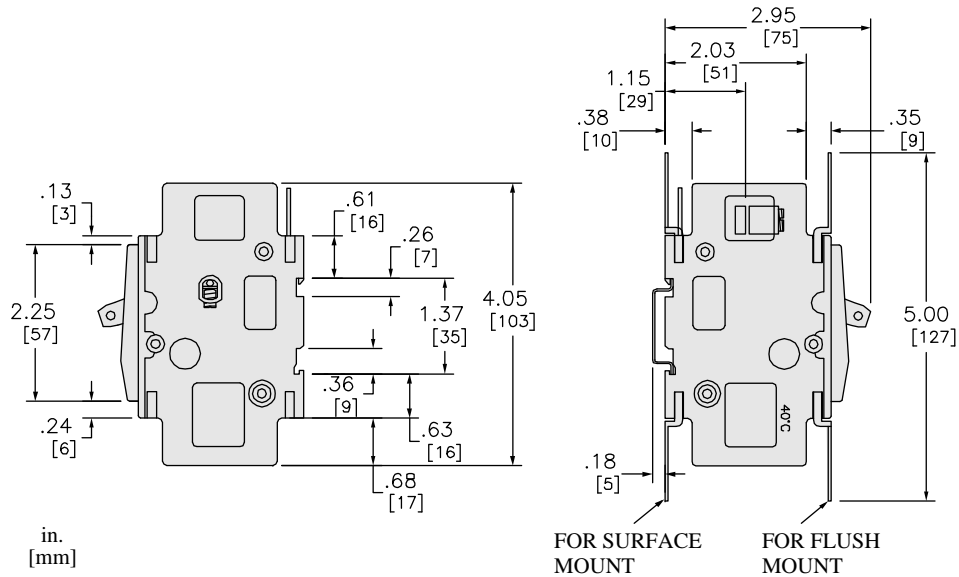

2.50 [64] MIN. WIRE BENDING SPACE FOR 2 AWG
 1.50 [38] MIN. WIRE BENDING SPACE FOR 14 AWG
 TYP. BOTH ENDS FOR ALL CB'S SHOWN
 PER ARTICLE 430-1-(B) NEC

[DIMENSIONAL EXAMPLE ONLY BELOW]

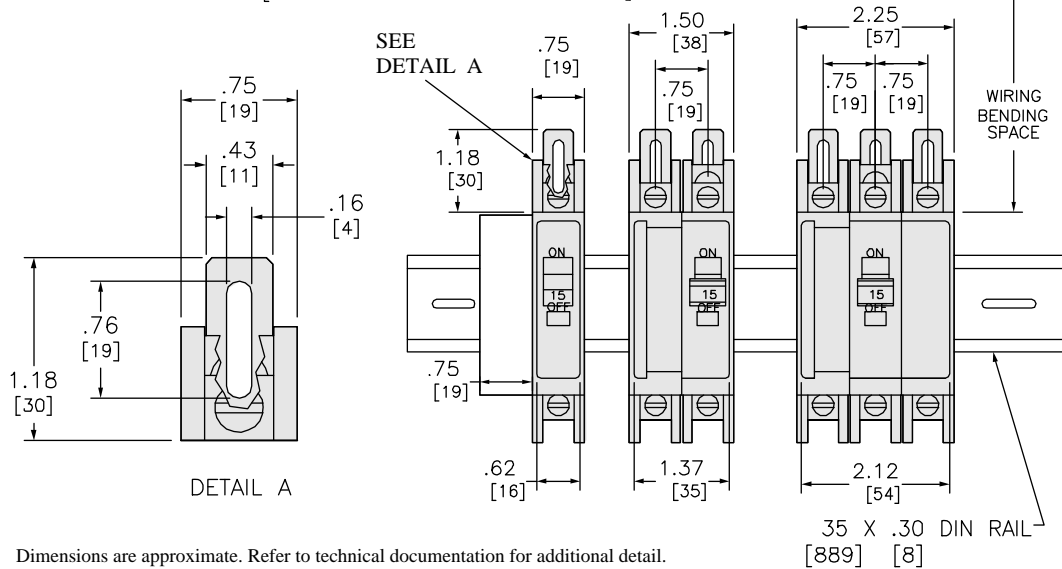

Dimensions are approximate. Refer to technical documentation for additional detail.